

2162 L

SINGLE POINT LOAD CELL "OFF CENTER"

- Capacity range till 150 kg
- Maximum platform till 400 x 400 mm
- Off-Center
- Made of Aluminium alloy
- Protection IP 63
- Very competitive prices
- Easy to install
- Available in EEx ia IIC T4 / T6 certified version for use in hazardous area

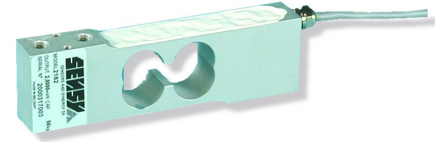

Model 2162 – 50 kg

The SENSY's load cell 2162L is perfectly designed to the following applications :

- Single point load cells for industrial scales and weighing system
- Retail and computing scales...
- Industrial platforms
- Filling, packaging and batching applications

AVAILABLE CAPACITIES :

2162L : 10 - 15 - 20 – (30) - 50 - (100) - (150) kg

TECHNICAL DATA		
Accuracy class		0.1 1000 d
Linearity error	% F.S.	< ± 0.1
Hysteresis error	% F.S.	< ± 0.1
Non - repeatability	% F.S.	< ± 0.03
Creep error over 30 min.	% F.S.	< ± 0.06
Zero shift after loading	% F.S.	< ± 0.015
Reference temperature	°C	23
Nominal temperature range	°C	- 10...+ 45
Service temperature range	°C	- 30...+ 70
Storage temperature range	°C	- 50...+ 85
Temperature coefficient of the sensitivity	% /10°C	< ± 0.05
Temperature coefficient of zero signal	% F.S./10°C	< ± 0.035
Nominal sensitivity	mV/V	2
Zero balance	mV/V	± 0.02
Sensitivity tolerance (g=9,8107 m/s ²)	%	< ± 0.3
Input / Output resistance	Ohm	351 ± 2
Insulation resistance (50V)	MOhm	> 5000
Nominal excitation voltage	V	5 to 10
Nominal range of the excitation voltage	V	2...15
Safe load limit	% F.S.	150
Breaking load	% F.S.	> 300
Static lateral force limit	% F.S.	
Permissible dynamic loading	% F.S.	50

F.S.: full scale Specifications subject to change without notice

LOAD CELL

model 2162L aluminium alloy

OFF-CENTER

Range 10 – 150 kg IP63

Cable length : 2 m

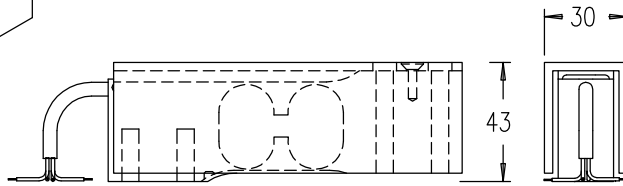
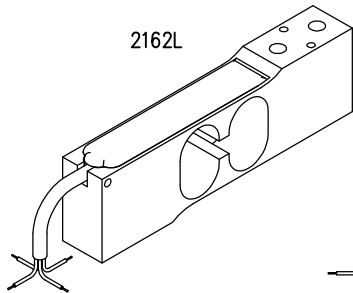
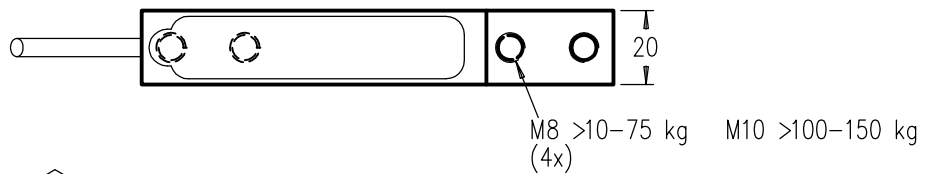
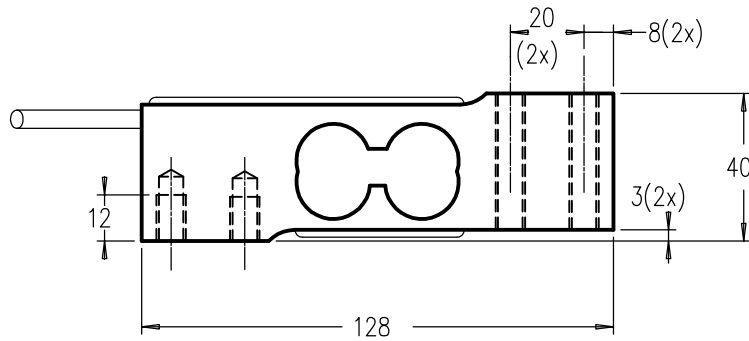

2162L-F
COVER OPTION

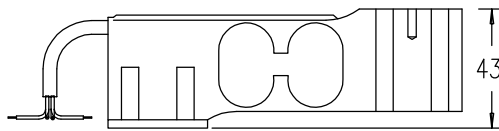
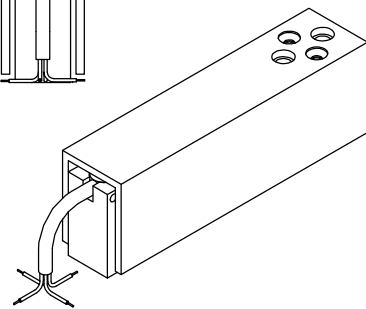

2162L-p Polyethylene plate

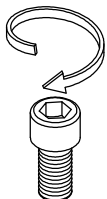
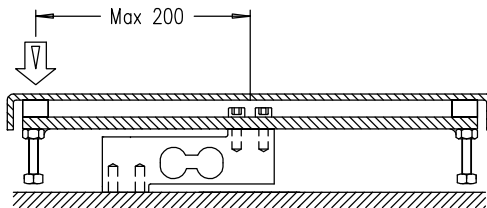

Note: Correct torque for fixing bolts : 10 Nm if M8 50 Nm if M10
(don't touch bottom of tapped holes)